

Separator body

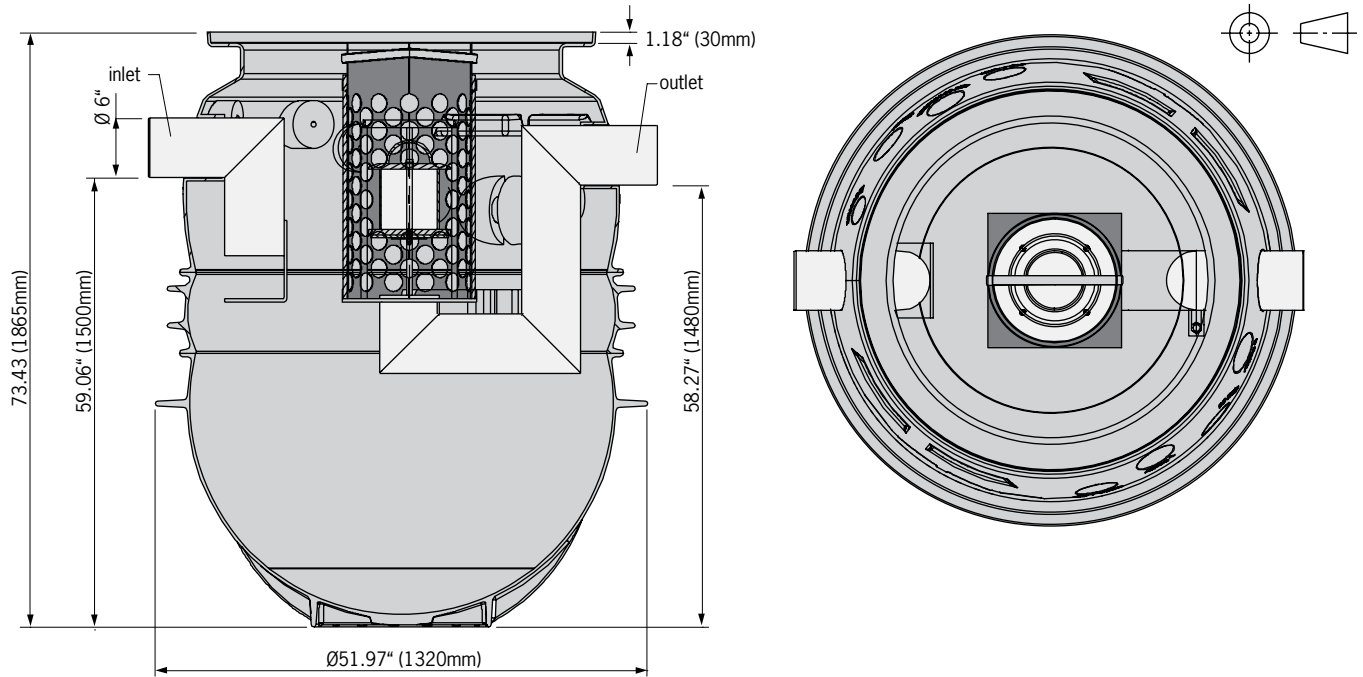

Model number	Maximum flow* L/s (gpm)	Volume solids trap L (gal)	Volume oil storage L (gal)	Total capacity L (gal)	Weight lbs	Part No.
NS6/660	6 (95)	660 (175)	235 (62)	970 (257)	200.2	3906.80.00

* Maximum flow indicated is for optimum performance - under 5mg/L hydrocarbons in effluent; higher flows can run through separator

Extension shafts & covers

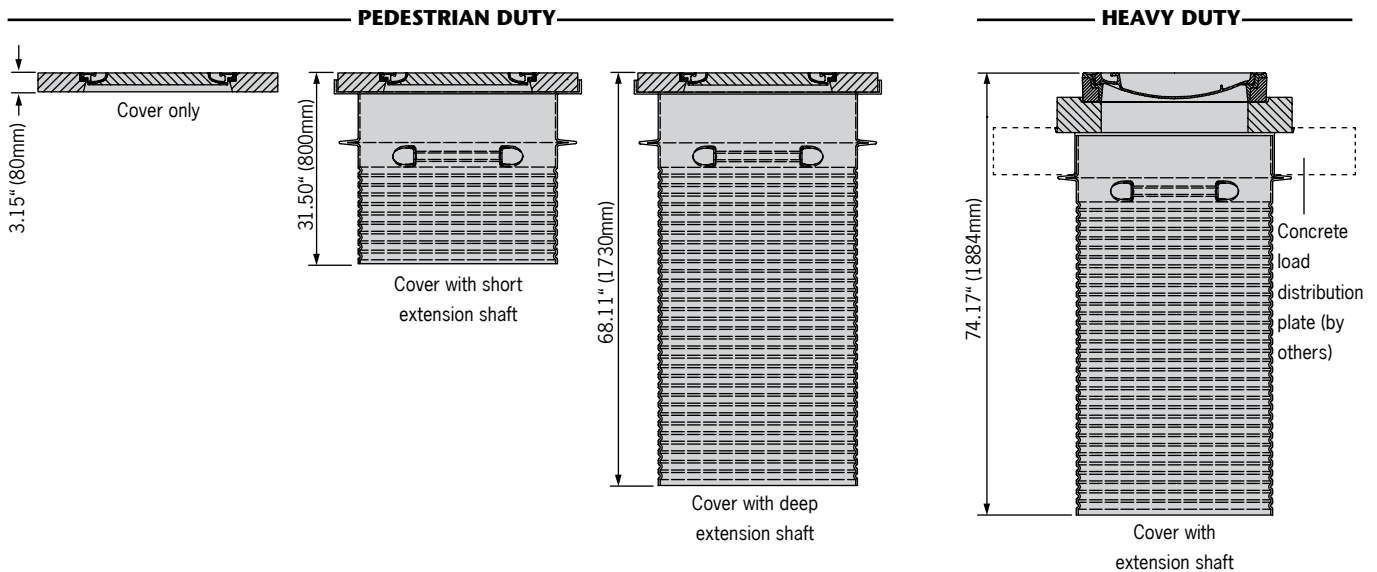

ACO Specification Information

ACO ENVIRONMENT

NS6/660 OLEOPATOR P - MDPE vertical body oil-water separator

Pedestrian Duty Top

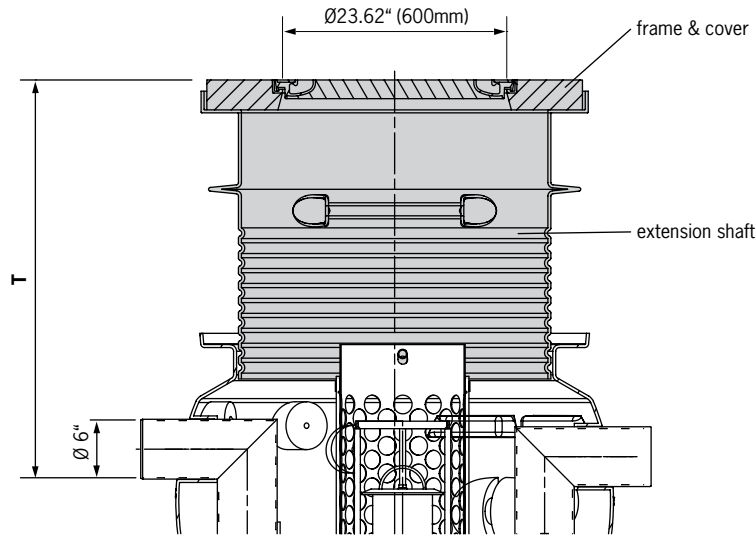

	T mm (inches)	Weight lbs	Part No.
Cover only	440 (17.3)	298.0	3301.14.00
Cover & short extension shaft	750-1050 (29.5-41.3)	376.2	3301.14.01
Cover & deep extension shaft	750-1800 (29.5-70.9)	424.8	3301.14.02

Heavy Duty Top

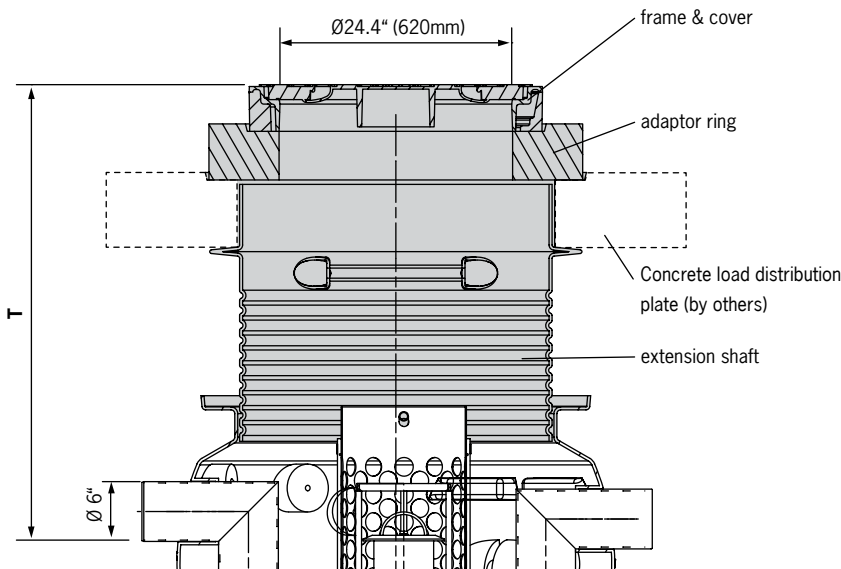

	T mm (inches)	Weight lbs	Part No.
Cover & extension shaft	885-1790 (34.8-70.5)	627.0	3301.17.00

NOTE: 1500mm (59in) diameter x 200mm thick concrete load distribution plate by others

Specifications

General

The oil water separator shall be **ACO Oleopator P NS6/660** complete with ductile iron cover as manufactured by ACO, Inc.

Materials

The separator body shall be manufactured from medium density polyethylene (HDPE) and have minimum properties as follows:
 Tensile impact strength: 152 ft-lb/in²
 Tensile strength, ultimate: 3,480 psi
 Water absorption 0.01%
 Frost proof, salt proof and fuels and oils resistant

The oil separator shall be equipped with a coalescing unit and automatic shut-off valve for situations when maximum oil capacity is reached. Minimum oil storage capacity shall be 235 Liters (62 gal); minimum suspended solids storage capacity shall be 660 Liters (175 gal). Separator shall be resistant to uplift forces from underground water up to finished grade water table level. The oil separator should not require a concrete surround.

Performance

The effluent water should contain maximum 5mg/L (5ppm) for maximum designed flow. Independent performance testing should be available on request.

Cover

Cover shall be manufactured from ductile iron to ASTM A 536-84 – Grade 65-45-12 and have a minimum inside opening diameter of 600mm (24in). The cover should be marked 'Separator' on the top. The cover shall be capable of withstanding pedestrian / heavy vehicle traffic*.

Distance from finished grade to inlet pipe invert (T) shall be . . . mm (. . . in). (see tables for values).

Accessories

The separator shall be equipped with high liquid level alarm / maximum oil capacity alarm / maximum suspended solids capacity alarm** systems.

Installation

Separator shall be installed in strict accordance with the manufacturer's installation instructions and recommendations.

* Choose one /** Choose none, one or more

ACO, Inc.
Northeast Sales Office
 9470 Pinecone Drive
 Mentor, OH 44060
 Tel: (440) 639-7230
 Toll free: (800) 543-4764
 Fax: (440) 639-7235

West Sales Office
 825 W. Beechcraft St.
 Casa Grande, AZ 85122
 Tel: (520) 421-9988
 Toll Free: (888) 490-9552
 Fax: (520) 421-9899

Southeast Sales Office
 4211 Pleasant Road
 Fort Mill, SC 29708
 Toll free: (800) 543-4764
 Fax: (803) 802-1063



Electronic Contact:
 info@acousa.com
 www.acousa.com

